

# Scaling Digital Services for Heat Pump Systems

*Lasse Thomsen, 04072024*

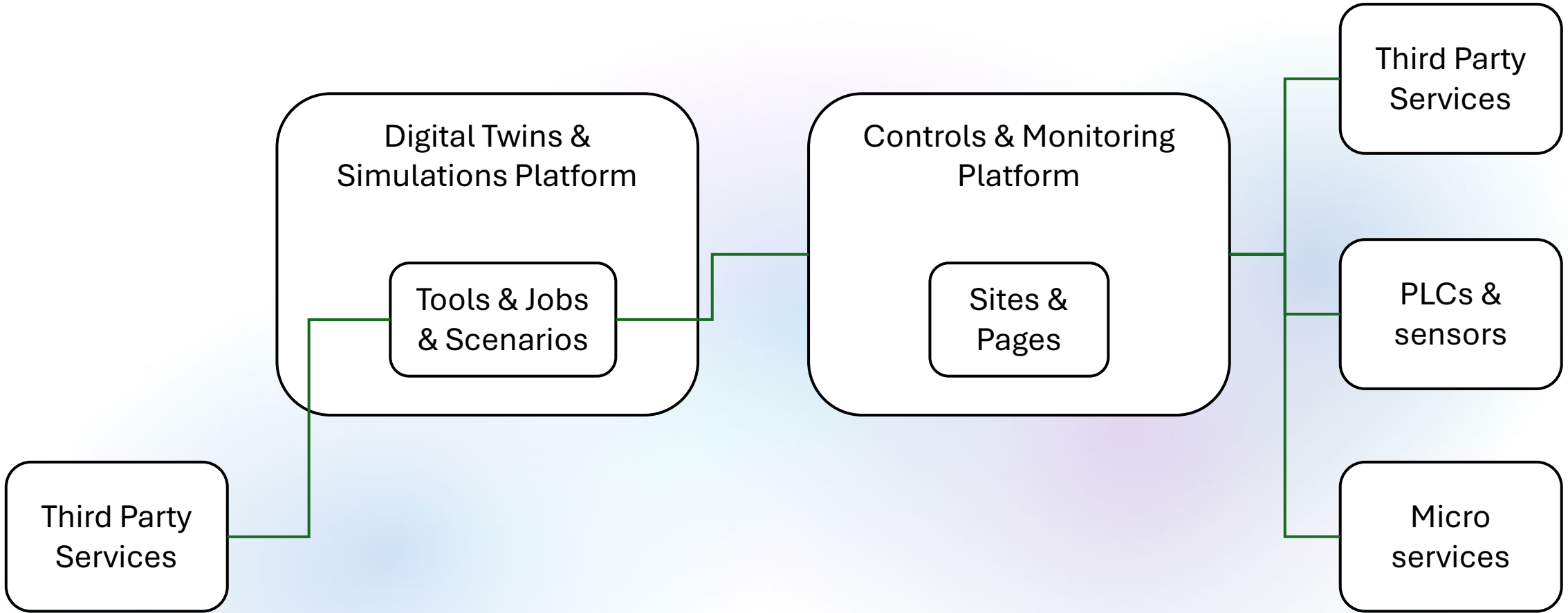

# Example 1: Energy Machines Verification (EMV) Micro Service

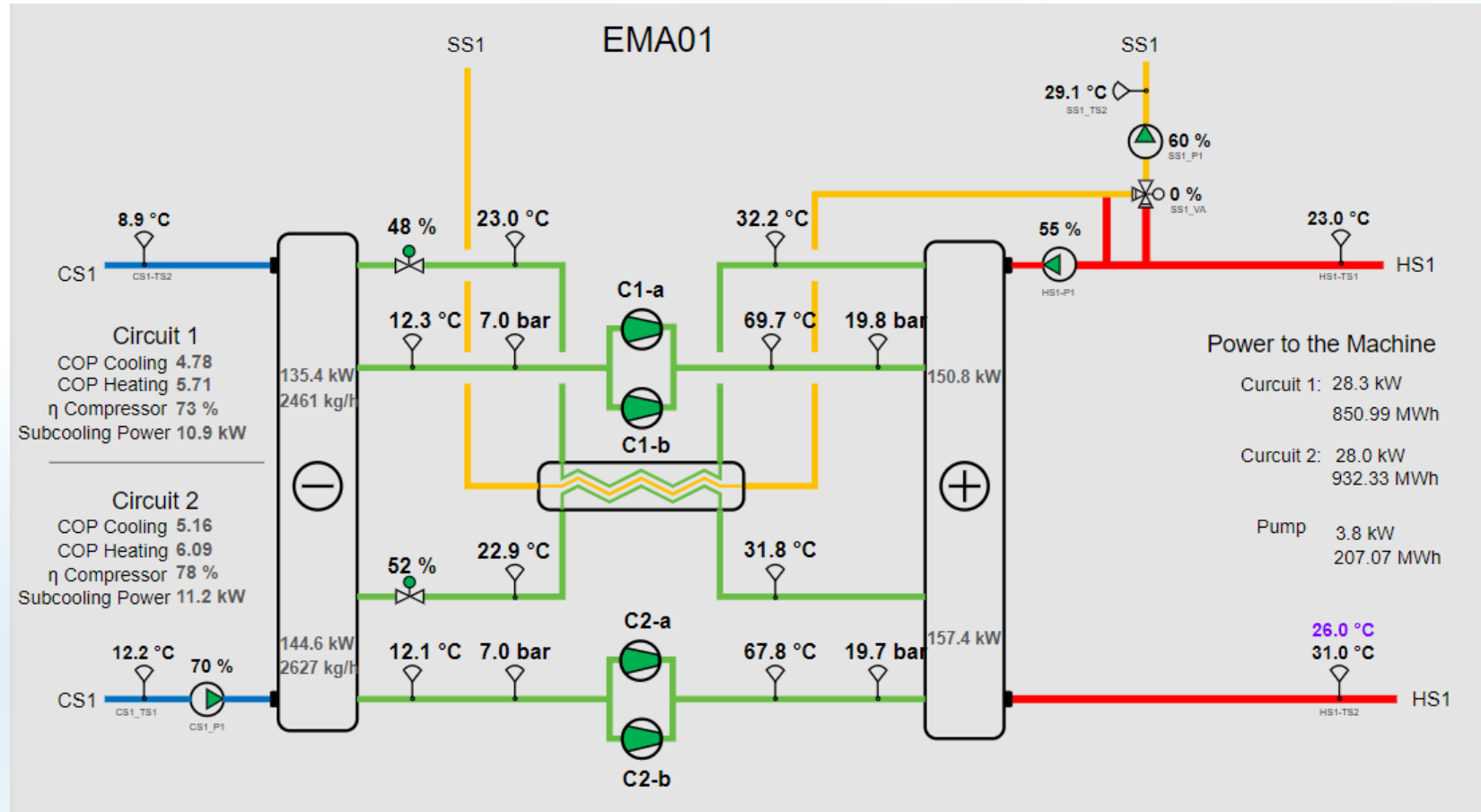

80 circuits online

6 refrigerants

6 circuit types



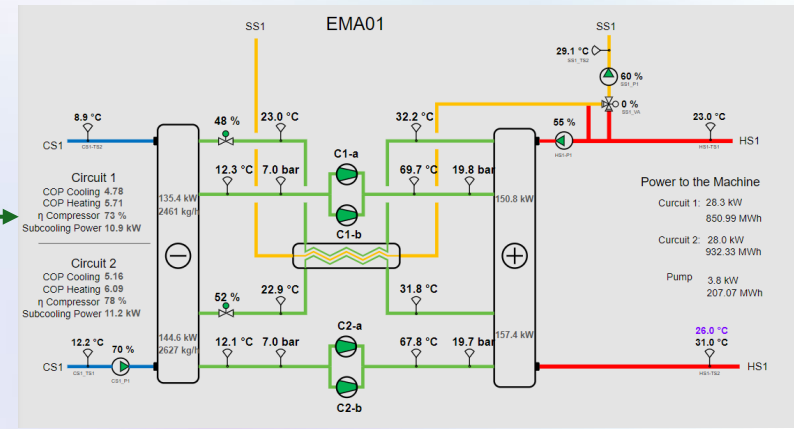
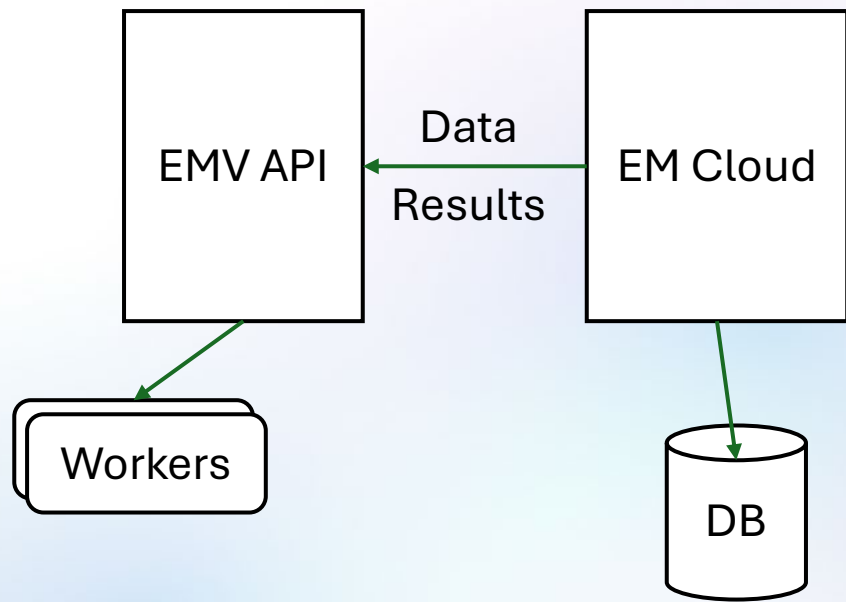

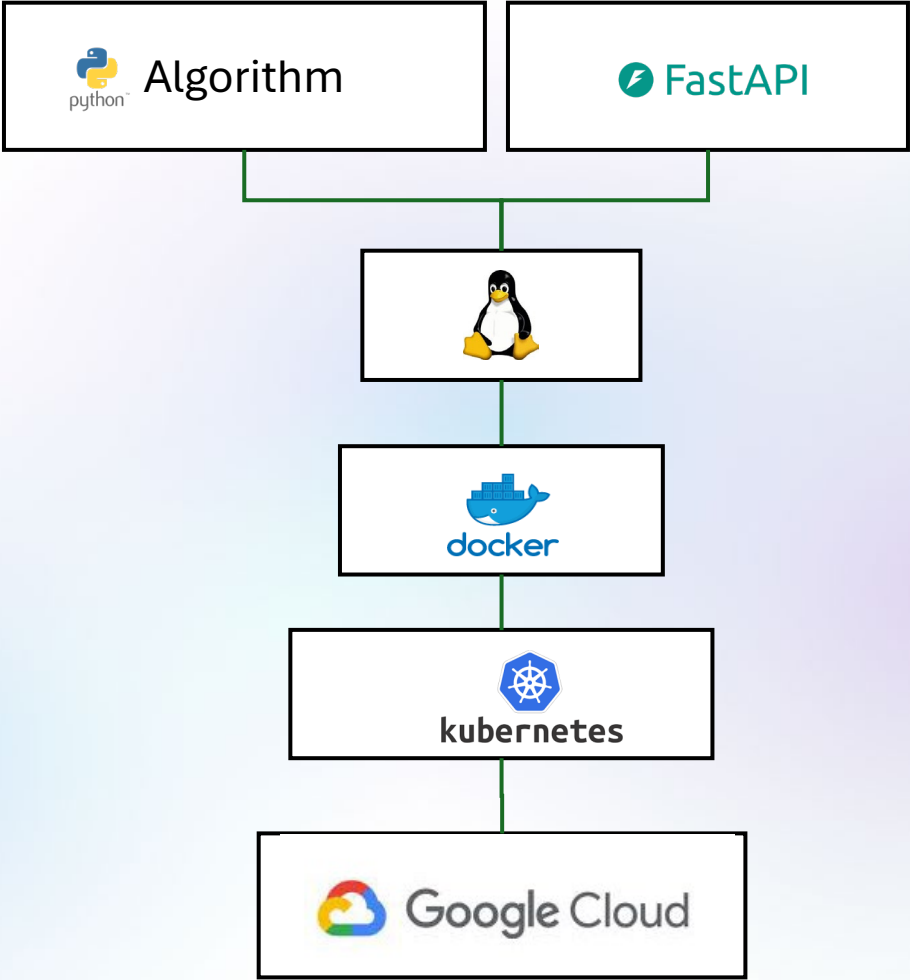



# Modularity



- The API can be used for offline processing, testing and validation
- The code base of EMV and the Controls Systems are separated
- The service is simple to integrate for third parties

# Example 2: Monitoring Thermal Storage Performance

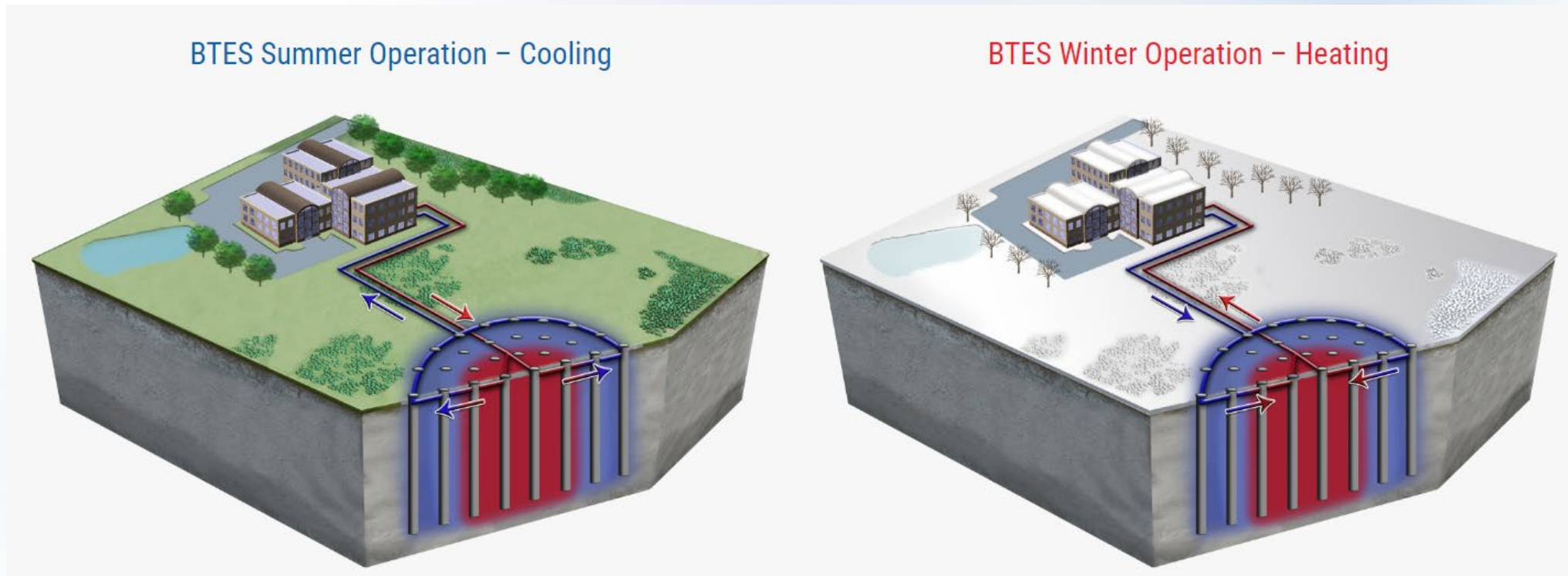

From [underground-energy.com](http://underground-energy.com)





## Value

- Monitoring operations and performance
- Ensuring sustainable operations for many years
- Analyzing potential in the storage
  - Possible cooling and heating loads

## Service

Interactive HTML Report in Controls System updated Daily

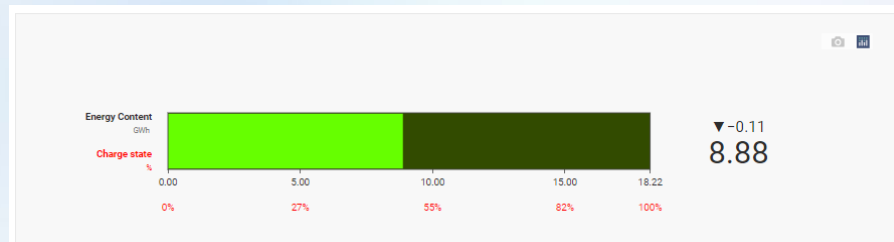

### Forecast

Forecast until operational end (2043-01-01 00:00 UTC) is done using input data from the last 3 years (i.e. [2021-04-08 10:00 UTC - 2024-04-08 10:43 UTC] repeated until 2043-01-01 00:00 UTC)

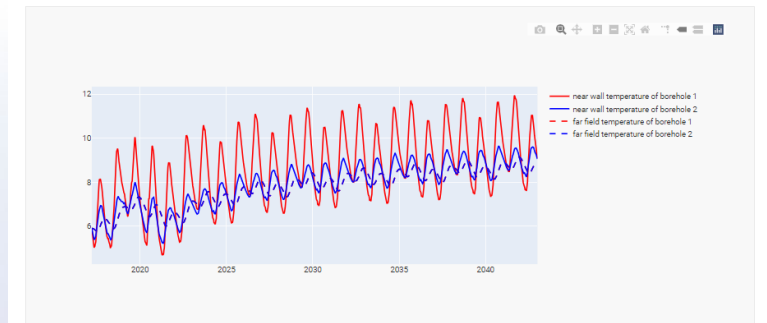

Figure 2: Near wall (solid) and far (dash) field temperatures of borehole(s)

Note: Two or more boreholes will have same far field temperature, as the ground spreads out the heat.

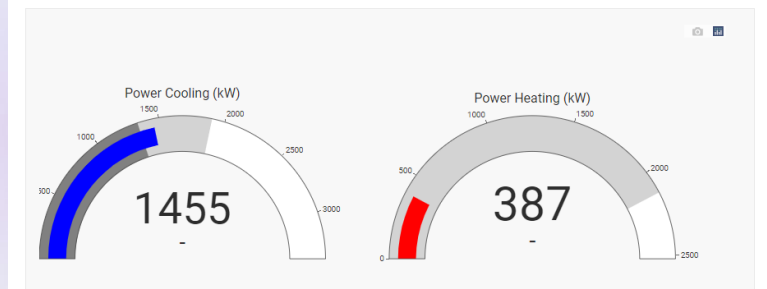

Figure 3: left: Forecasted hourly maximum cooling power demand within the next 14 days from 2024-06-30 12:00 UTC (blue), and maximum available cooling power during that period (grey) right: Forecasted hourly maximum heating power demand within the next 14 days from 2024-06-30 12:00 UTC (red), and maximum available heating power during that period (grey).

Note: The maxima are calculated as the power, which leads to an increase in borehole temperature near the well wall, up to an absolute value of 15°C, for cooling, whereas for heating, it is calculated as the power, which leads to a decrease in borehole temperature near the well wall, down to an absolute value of 0 °C.

- Recently viewed
- Tools
- Development
- Repositories
- Files
- Organization
- Settings
- Pinned
- Full Demand with bio...
- NUS By23 Borehole S...
- Run 2
- Your workspaces
- General
- Power To Heat
- Testing space
- Heat Pump Design...
- NUS
- Development
- EMV

Information

Information	
Name Digital Twin - NUS	<a href="#">Edit Name</a> <span style="float: right;"><a href="#">Move</a></span>
Description No description	<a href="#">Edit Description</a> <span style="float: right;">Workspace NUS</span>
Created by Lasse Thomsen	

Groups

dev No scenarios [Add Scenario](#)

production 5 scenarios | 11 archived scenarios [Add Scenario](#)

GROUP INFORMATION							
SCENARIO NAME	DATA OUTPUT	REPORTS	PROGRESS	LAST CHANGED	EDITED BY		
NUS forecast	No data yet	HTML HTML HTML	51.00%	01/07/2024 - 10:54	Tobias Elm�e		
nus gfunc correction	No data yet	HTML HTML	8.00%	01/07/2024 - 10:53	Tobias Elm�e		
Data NUS live	Available	N/A	hibernating	15/02/2024 - 09:31	Tobias Elm�e		
NUS By23 Borehole Storage Report	No data yet	HTML	hibernating	17/01/2024 - 10:11	Tobias Elm�e		
Data NUS historical	Available	N/A	finished	11/01/2024 - 12:43	Tobias Elm�e		

Datasets

Show

Add Dataset



# BTES Monitoring Service

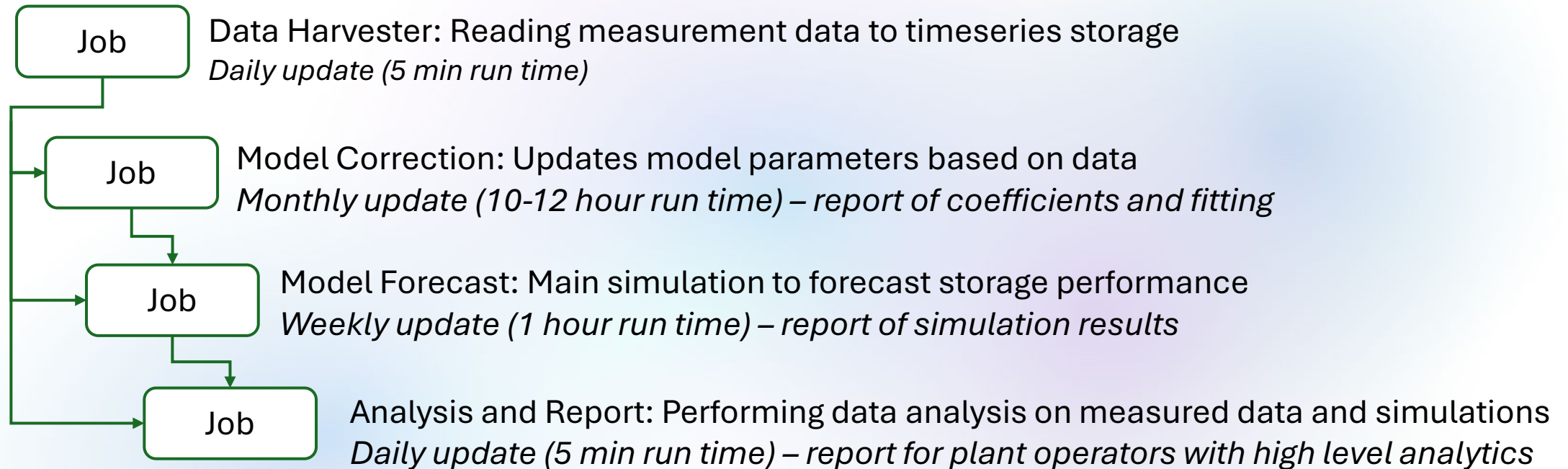

# Energy Machines Digital Twins & Simulations Platform

# Energy Machines Cloud Controls & Monitoring

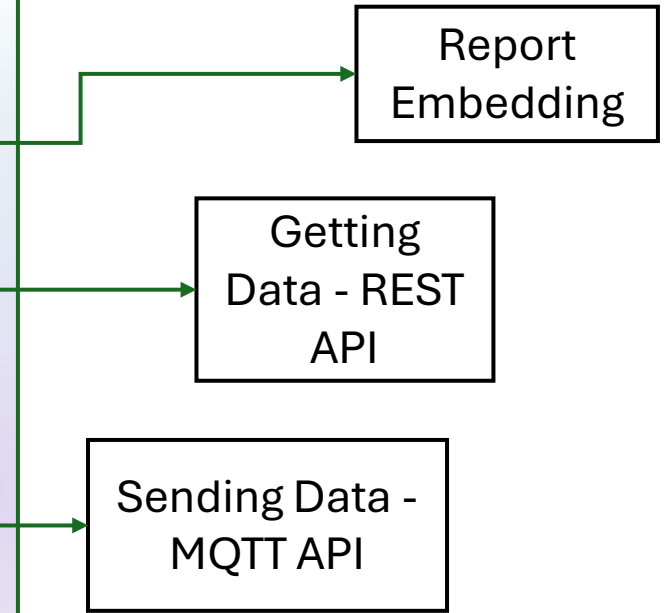
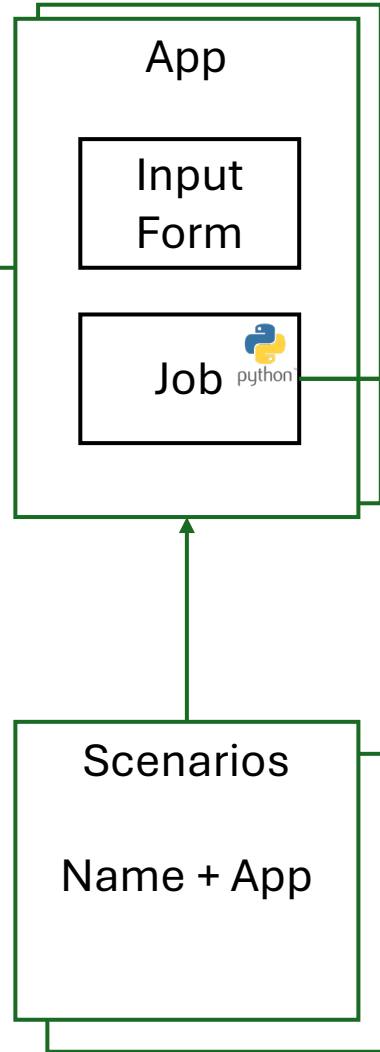
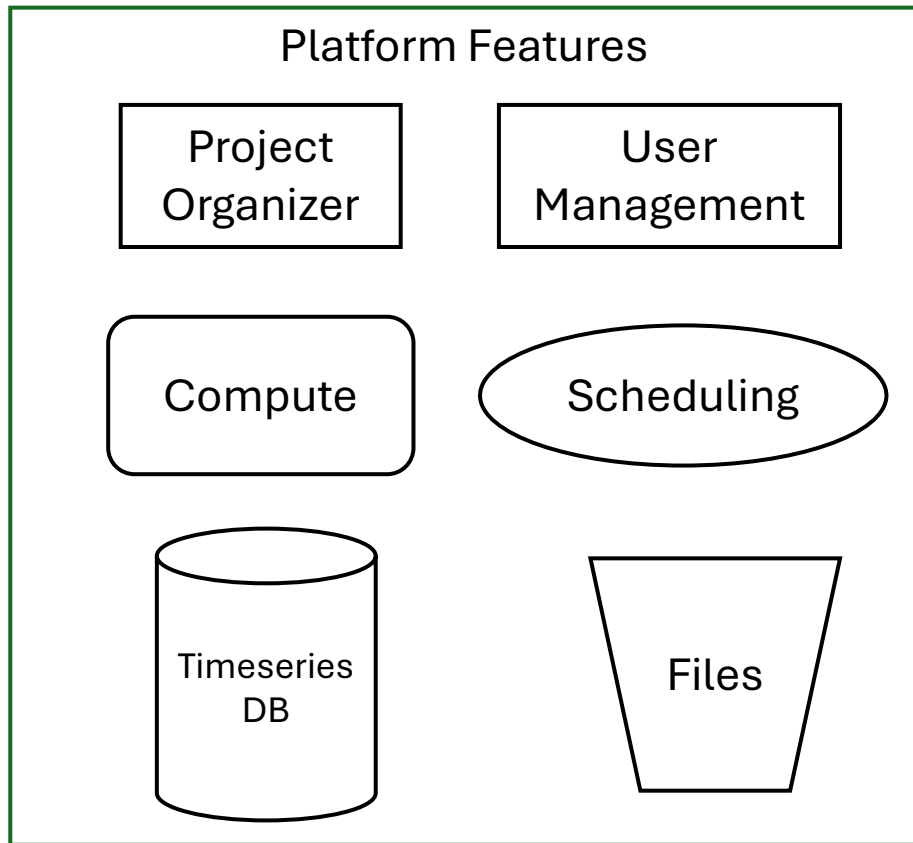

# Algorithm Developer

Apps & Jobs



```

1 # Landing page
2 # Landing page
3 # Landing page
4 # Landing page
5 # Landing page
6 # Landing page
7 # Landing page
8 # Landing page
9 # Landing page
10 # Landing page
11 # Landing page
12 # Landing page
13 # Landing page
14 # Landing page
15 # Landing page
16 # Landing page
17 # Landing page
18 # Landing page
19 # Landing page
20 # Landing page
21 # Landing page
22 # Landing page
23 # Landing page
24 # Landing page
25 # Landing page
26 # Landing page
27 # Landing page
28 # Landing page
29 # Landing page
30 # Landing page
31 # Landing page
32 # Landing page
33 # Landing page
34 # Landing page
35 # Landing page
36 # Landing page
37 # Landing page
38 # Landing page
39 # Landing page
40 # Landing page
41 # Landing page
42 # Landing page
43 # Landing page
44 # Landing page
45 # Landing page
46 # Landing page
47 # Landing page
48 # Landing page
49 # Landing page
50 # Landing page
51 # Landing page
52 # Landing page
53 # Landing page
54 # Landing page
55 # Landing page
56 # Landing page
57 # Landing page
58 # Landing page
59 # Landing page
60 # Landing page
61 # Landing page
62 # Landing page
63 # Landing page
64 # Landing page
65 # Landing page
66 # Landing page
67 # Landing page
68 # Landing page
69 # Landing page
70 # Landing page
71 # Landing page
72 # Landing page
73 # Landing page
74 # Landing page
75 # Landing page
76 # Landing page
77 # Landing page
78 # Landing page
79 # Landing page
80 # Landing page
81 # Landing page
82 # Landing page
83 # Landing page
84 # Landing page
85 # Landing page
86 # Landing page
87 # Landing page
88 # Landing page
89 # Landing page
90 # Landing page
91 # Landing page
92 # Landing page
93 # Landing page
94 # Landing page
95 # Landing page
96 # Landing page
97 # Landing page
98 # Landing page
99 # Landing page
100 # Landing page
  
```

# Application Engineer

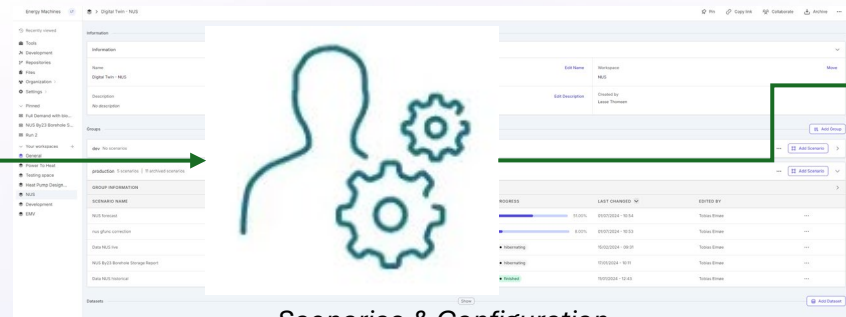
# Scenarios & Configuration

# Client

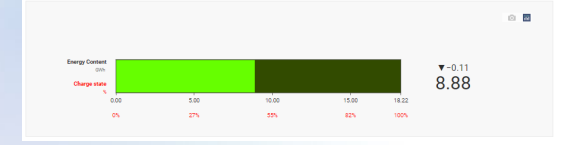
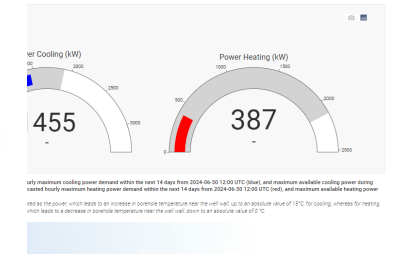
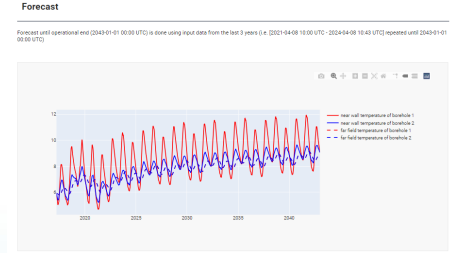

# Report & Dashboard in Controls System

# SW DevOps

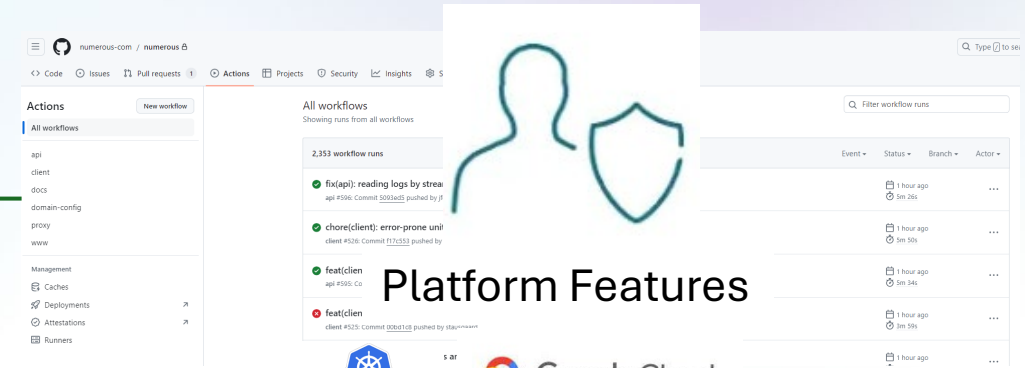
numerous-com / numerous

2,353 workflow runs

- fix(api): reading logs by stream
- chore(client): error-prone unit
- feat(client)
- feat(client)

# Platform Features



Thank you for your attention!



[www.numerous.com](http://www.numerous.com)



[www.energymachines.com](http://www.energymachines.com)

